

MATERIAL NOTES:

1. FILTER MEDIA: MICRO-GLASS FIBER / ACRYLIC RESIN BINDER
2. SEPARATOR MAT'L: CORRUGATED, 1145 ALUMINUM
3. FRAME MAT'L: 16 GAUGE 304 STAINLESS STEEL
4. SEALANT MAT'L: TWO PART HIGH TEMPERATURE CERAMIC POTTING COMPOUND
KAOWOOL, CERAMIC PAD
5. GASKET MATERIAL: 1/4 X 3/4 HIGH TEMPERATURE, CERAMIC, DOWNSTREAM SIDE.
6. SCREEN MATERIAL: 1/4 PERFORATED, 18 GAUGE 304 STAINLESS STEEL,
DOWNSTREAM

TESTING NOTES:

1. EACH FILTER SHALL BE TESTED FOR EFFICIENCY IN ACCORDANCE WITH IEST-RP-CC-007.
2. FILTER MEETS IEST-RP-CC001 TYPE H PERFORMANCE LEVEL.

FILTER SPECIFICATIONS:

PLEAT DEPTH (IN): 5-3/16 NOMINAL
 EFFICIENCY: 99.97% MIN vs. 0.2-0.3 micron
 MAX. OPERATING TEMP: 750°F
 MAX. REL. HUMIDITY: 99%

UL RATING:

1. FILTERS MEET UL-900

FRAME TOLERANCES:

LENGTHS: +0, -1/8"
 DIAGONALS: WITHIN 1/8" TOTAL ALLOWANCE FOR DIAGONALS < 30 in.
 WITHIN 1/4" TOTAL ALLOWANCE FOR DIAGONALS ≥ 30 in.

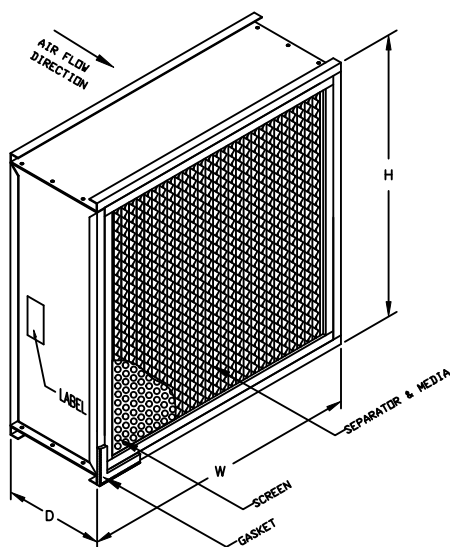

DESCRIPTION	SIZE (H x W x D) (in inches)	CAPACITY (CFM) @ 1.00 IN. W.C.	PART NUMBER
01FS-12Z12Z06-5D-2-E-A-2D-0/00	12 x 12 x 5-7/8	110	855220130
01FS-22H34H06-5D-2-E-A-2D-0/00	22-1/2 x 34-1/2 x 5-7/8	800	855227198
01FS-30Z30Z06-5D-2-E-A-2D-0/00	30 x 30 x 5-7/8	940	SUBMITTAL
01FS-24Z24Z06-5D-2-E-A-2D-0/00	24 x 24 x 5-7/8	570	855220093
01FS-20Z36Z06-5D-2-E-A-2D-0/00	20 x 36 x 5-7/8	730	85502XXXX
01FS-24Z30Z06-5D-2-E-A-2D-0/00	24 x 30 x 5-7/8	730	855227202
01FS-24Z18Z06-5D-2-E-A-2D-0/00	24 x 18 x 5-7/8	410	855221467
01FS-30Z24Z06-5D-2-E-A-2D-0/00	30 x 24 x 5-7/8	730	855220287
01FS-30Z30Z06-5D-2-E-A-2D-0/00	30 x 30 x 5-7/8	940	855220288
01FS-18B13L06-5D-2-E-A-2D-0/00	18-1/8 x 13-3/4 x 5-7/8	210	SUBMITTAL
01FS-12Z24Z06-5D-2-E-A-2D-0/00	12 x 24 x 5-7/8	250	855221469
01FS-18H19H06-5D-2-E-A-2D-0/00	18-1/2 x 19-1/2 x 5-7/8	340	85522XXXX
01FS-18Z24Z06-5D-2-E-A-2D-0/00	18 x 24 x 5-7/8	410	855227228
01FS-31Z18Z06-5D-2-E-A-2D-0/00	31 x 18 x 5-7/8	550	85522XXXX
01FS-20Z20Z06-5D-2-E-A-2D-0/00	20 x 20 x 5-7/8	380	85522XXXX
01FS-24Z36Z06-5D-2-E-A-2D-0/00	24 x 36 x 5-7/8	900	85522XXXX
01FS-18Z30Z06-5D-2-E-A-2D-0/00	18 x 30 x 5-7/8	530	85522XXXX
01FS-18Z36Z06-5D-2-E-A-2D-0/00	18 x 36 x 5-7/8	640	85522XXXX
01FS-36Z24Z06-5D-2-E-A-2D-0/00	36 x 24 x 5-7/8	900	85522XXXX
01FS-24Z48Z06-5D-2-E-A-2D-0/00	24 x 48 x 5-7/8	1220	85522XXXX
01FS-34D22D06-5D-2-E-A-2D-0/00	34-1/4 x 22-1/4 x 5-7/8	780	85522XXXX
01FS-08Z08Z06-5D-2-E-A-2D-0/00	8 x 8 x 5-7/8	30	85522XXXX
01FS-35Z23Z06-5D-2-E-A-2D-0/00	35 x 23 x 5-7/8	830	85522XXXX
01FS-18Z18Z06-5D-2-E-A-2D-0/00	18 x 18 x 5-7/8	300	855220378
01FS-18B18B06-5D-2-E-A-2D-0/00	18-1/8 x 18-1/8 x 5-7/8	300	85522XXXX
01FS-11J11J06-5D-2-E-A-2D-0/00	11-5/8 x 11-5/8 x 5-7/8	100	85522XXXX
01FS-23J23J06-5D-2-E-A-2D-0/00	23-5/8 x 23-5/8 x 5-7/8	550	85522XXXX
01FS-22Z24Z06-5D-2-E-A-2D-0/00	22 x 24 x 5-7/8	520	85522XXXX

CUSTOMER APPROVAL BLOCK			
YOUR APPROVAL OF THIS PRINT AUTHORIZES CAMFIL USA INC. TO PROCEED WITH MATERIAL PROCUREMENT, TOOLING AND PRODUCT FABRICATION. ANY CHANGES MADE AFTER APPROVAL MAY INCUR FURTHER EXPENSES TO THE CUSTOMER			
<input type="checkbox"/> OK AS IS		<input type="checkbox"/> SEND REVISED DWG.	
SIGNATURE/DATE: _____			
COMPANY NAME: _____			
APPROVED BY:	DATE:	DRAWN BY:	DATE:
JC	10/29/09	TG	10/29/09
SHEET		DRAWING NUMBER	
1 of 1		501220	
			REV.
			-



©Camfil USA Inc. <http://www.camfil.com>

DESCRIPTION
ABSOLUTE
F SERIES